

SM3 ^{EN}

X-Series



CAMPETELLA

Side entry Robot SM3 X-Series evo

125
Years

our history, our strength

 *Campetella,
the right way
to save energy.*

FOLLOW US:



Xseries
EVO

SM3 X-Series evo

The high-versatility side-entry robot with maximum sturdiness

SM3 X-Series is a high-performance robot that can combine the typical productivity of side-entry robots with versatility features that are revolutionary for this category. Its unprecedented architecture, with a solid anchoring to the ground and plenty of travel in all three directions, is a change in the paradigm of flexibility of use for side-entry robots. Its structure is more rigid and massive than that of its little brother, the SM2, and it has a double support column and even longer travels. This means the possibility to run fast cycles with higher payloads.

Self-lubricating sliding blocks with roll-by balls on carbon steel prismatic guides

Pneumatic balancing of vertical axis



Console EVO

Light and ergonomic, with a 7" TFT 800x480 wide range touch screen and a membrane keyboard, it allows to program and manage all the robot functions in a simple and intuitive way.

Through a simple wizard, it quickly guides the user through the creation of IMM unloading cycles with palletizing functions. In order to encourage more complex work cycles, we use a powerful editor, which allows to access all the available functions. The EVO software offline version is also available to be installed on a PC in order to permit the offline programming and the remote connection to the robot.

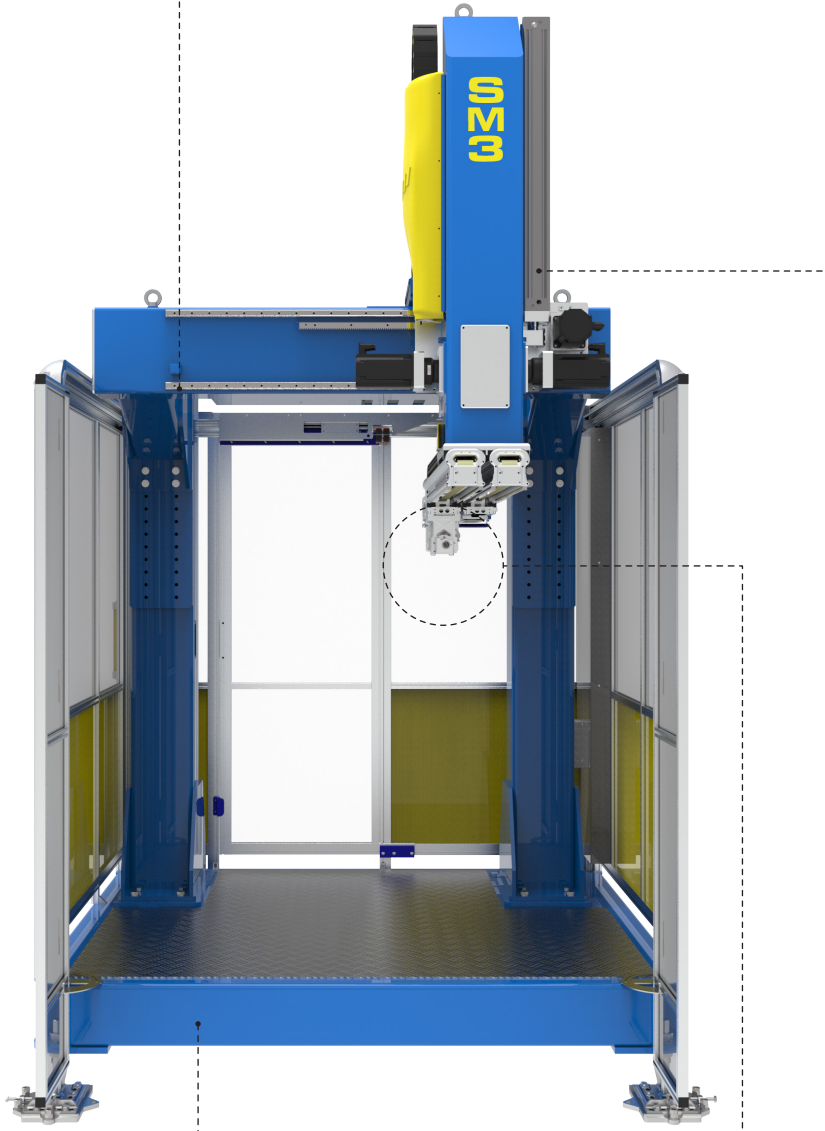

Sturdy base for resting on floor

Pneumatic C-axis
Maximum Payload 6+6 Kg

Electrical cabinet on the ground



Float
Balanced Axis

Carbon
Technology

Dynamic
Vacuum

K.E.R.S.

H.S.I.

3DP
Device

V.O.S.

Jog Over

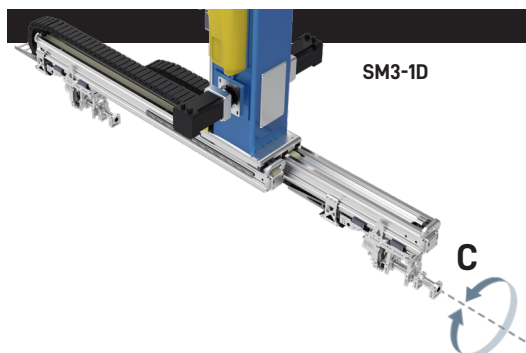

SM3-1D

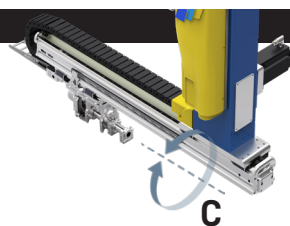

SM3-10

C pneumatic axis

The C pneumatic axis facilitates the deposit in plan of the molded pieces picked up from the mold, choosing from the program between two positions (vertical/horizontal).

(sample image may differ from actual supply)

Technical specifications		
Maximum payload [kg]:	12	2 axes x 6
Vertical axis:		Direct
Vertical axis pneumatic balancing:	•	•
Z-axis stroke - Horizontal [mm]:	2400	2 axes x 2400
X-axis stroke - Extraction [mm]:		800
Y-axis stroke - Vertical [mm]:		800
X, Y, Z axes motion:	AC synchronous brushless servo motors	
X,Y,Z axes guidance system:	Self-lubricating sliding blocks with roll-by balls on carbon steel prismatic guides	
Positioning repeatability [mm]:		± 0,1
Pneumatic C axis rotation [deg]:		0°/90°
Electrical C axis rotation [deg]:	0° + 270°	-
Pneumatic AB axis rotation [deg]:		-
Electrical AB axis rotation [deg]:		-
Electrical B axis rotation [deg]:		-
Pneumatic C axis torque [Nm]:	48	24
Pneumatic AB axis torque [Nm]:		-
Electrical C axis torque [Nm]:	58,6	-
Electrical AB axis torque [Nm]:		-
Electrical B axis torque [Nm]:		-
Control unit:	Campetella EVO proprietary system	
Minimum cycle time with maximum load [s]:		6,0
Electrical power supply:	400-480 VAC • 50-60Hz • 3P+T	
Installed electrical power [kVA]:	22,95	30,60
Pneumatic power supply [bar]:		6
Approximate weight [kg]:		2200

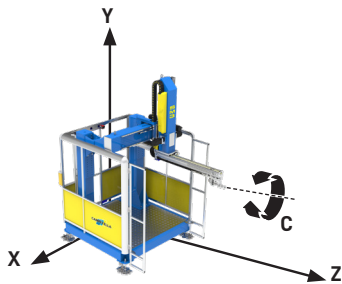
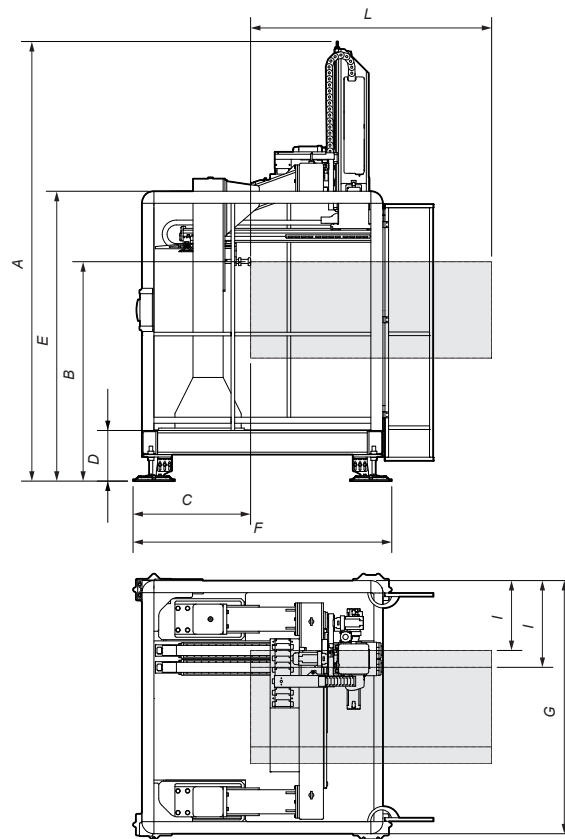

Model	A	B	C	D	E	F	G	H	I	L	M
SM3-10	3680	1750	1015	420	2405	2100	2100	N/A	640	2400	N/A
SM3-1D	3650	1820	950	420	2400	2100	2100	N/A	580/720	2400	N/A

The drawings refer to a robot SM31-0

	SM3-10	SM3-1D
Wrist		
Pneumatic C-axis	●	●
Pneumatic C-axis + Pneumatic AB-axis	○	-
Pneumatic C-axis + Electric B-axis	-	-
Pneumatic C-axis + Pneumatic AB-axis + Electric B-axis	-	-
Electric C-axis + Electric AB-axis	-	-
Gripping system Pneumatics		
First vacuum circuit with release blows	●	●
First pressure circuit for mechanical gripper	●	●
Additional vacuum circuits with release blows (n.2 max) (2)	○	○
Additional pressure circuits for mechanical gripper (n.3 max) (2)	○	○
Kit 4 valves 5/2 monostable + 12 input on the wrist	-	-
Kit 4 valves 5/2 bistable + 12 input on the wrist	-	-
Kit 8 valves 5/2 monostable + 12 input on the wrist	-	-
(2) Up to a maximum of 6 pneumatic lines total		
Electronics and Software		
Euromap 67 interface	●	●
Ethernet interface	●	●
USB interface	●	●
Socket for digital signals on the wrist: 5 (Programmable Input/Output) + 2(Input)	●	●
Socket for user safety signals	●	●
Socket for conveyor belt signals: 1 (Input) + 2 (Output) + 1 (Relais Output)	●	●
Socket for digital signals: 4 (Input) + 3 (Output relay)	●	●
Proximity sensor for transversal axis	●	●
Industry 4.0 kit (ethernet router + software)	○	○
Board kit I/O external 16I + 16O with 8mt cable	○	○
Electrical panel on board	-	-
Electrical cabinet on the ground	●	●
Ground cabinet air conditioning	○	○
IML ready with high-voltage cable (high-voltage wiring for IML predisposition) (3)	○	○
PLC software integrated into the CNC	○	○
Off-line programming software	○	○
Electrowelded steel robot support base:	●	●
Safety protections with system and interface Euromap 73:	●	●

Accessories**IMM connecting cable:**

For Euromap 67 interface, available lengths [m]: 10 (●) 12 (○) 14 (○)

For JIS interface, available lengths [m]: 10 (○)

Pushbutton remote control panel for basic functions (○)**EVO console cable winder (○)**

● Standard ○ Optional - Not available