

ME1^{EN}

PRIME-Series



CAMPETELLA

Linear Robot ME1 PRIME Series

125
Years

our history, our strength



Campetella,
the right way
to save energy.

FOLLOW US:



Prime series

ME1 PRIME-Series

The compact robot for small and medium-sized tonnage injection molding machines

The ME1 PRIME Series model is recommended for the automation of small and medium tonnage injection molding machines. The vertical axis group is frontally fixed on the extraction axis. This results in reduced overhangs, high mechanical balance and total absence of collision problems between the article and the extraction axis.

Roller bearings on hardened steel prismatic guides and sliding blocks with roll-by balls

Console PRIME

The User interface is characterised by a portable ergonomic console manufactured in carbon fibre to minimise weight and maximise strength; it is connected by a 5 m cable. It has a 4.3" graphical colour display with knob for browsing the menus, keys dedicated to direct movement of the axes, safety button and operator presence button.

Furthermore, the presence of a USB port allows copying, exporting and importing of the "work files" and the "set-ups" on computer or other robots.

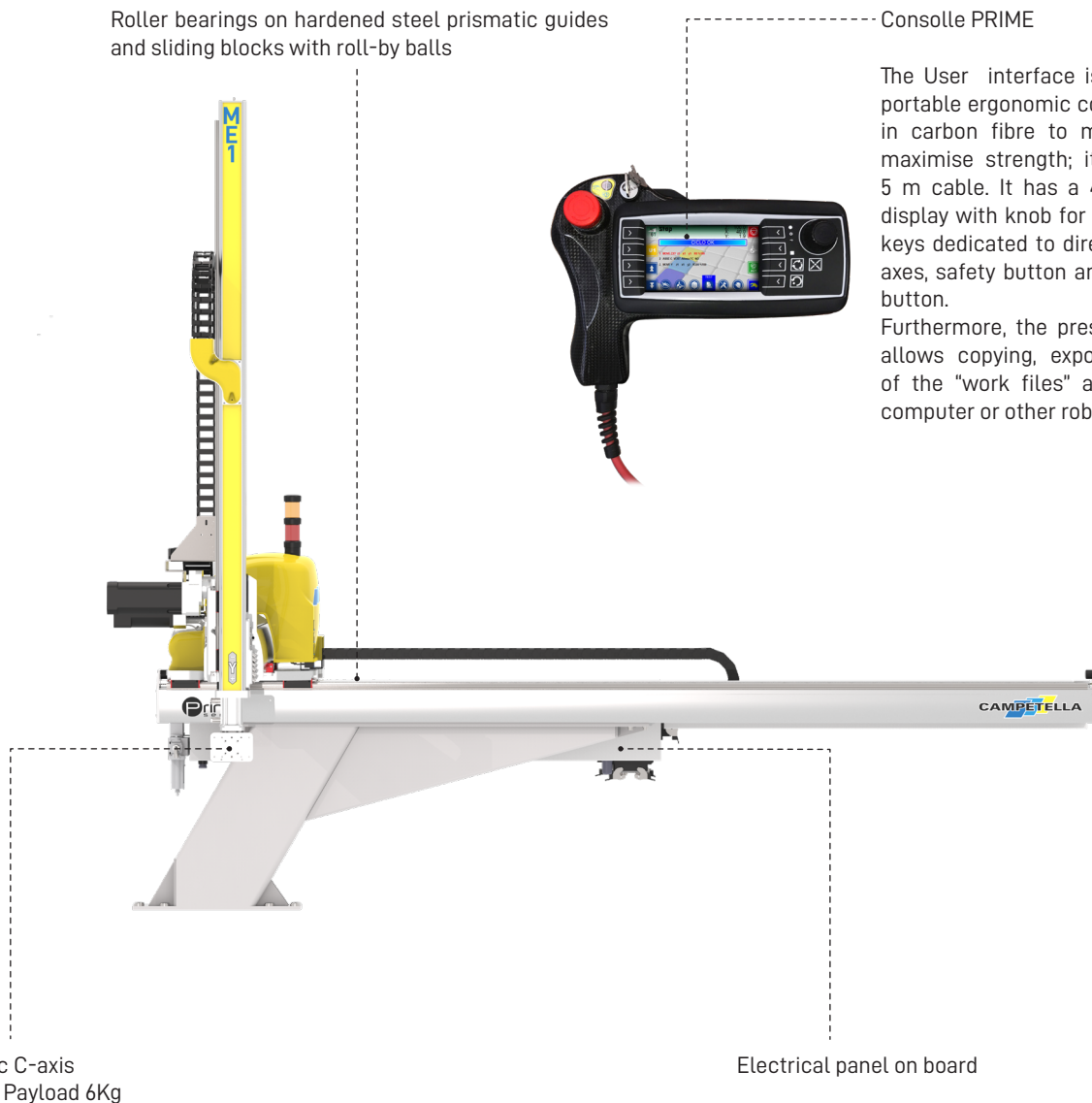

Float
Balanced Axis

Carbon
Technology

Dynamic
Vacuum

K.E.R.S.

H.S.I.

3DP
Device

V.O.S.

Jog Over

Pneumatic C Axis

The C pneumatic axis facilitates the deposit in plan of the molded pieces picked up from the mold, choosing from the program between two positions (vertical/horizontal).

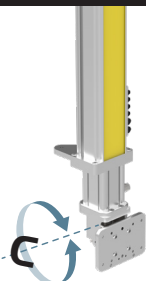

(sample image may differ from actual supply)

Asse AB pneumatico

For applications that require it, it is possible to choose the wrist with the additional pneumatic axis AB, which allows the rotation on its axis of the end of tool arm by choosing from the program between two positions mechanically fixed on the 0° -90° or 0° -180°

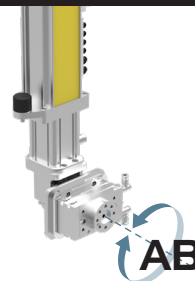

(sample image may differ from actual supply)

Technical specifications			
Maximum payload [kg]:	6		6
Vertical axis:	Direct		Direct
Vertical axis pneumatic balancing:	-		-
Z-axis stroke - Horizontal [mm]:	1500		2000
X-axis stroke - Extraction [mm]:		600	
Y-axis stroke - Vertical [mm]:	1200		1200
X, Y, Z axes motion:	AC synchronous brushless servo motors		
X,Y,Z axes guidance system:	Roller bearings on hardened steel prismatic guides and sliding blocks with roll-by balls		
Positioning repeatability [mm]:		± 0,1	
Pneumatic C axis rotation [deg]:		0°/90°	
Electrical C axis rotation [deg]:		-	
Pneumatic AB axis rotation [deg]:		0°+180°	
Electrical AB axis rotation [deg]:		-	
Electrical B axis rotation [deg]:		-	
Pneumatic C axis torque [Nm]:		16	
Pneumatic AB axis torque [Nm]:		1	
Electrical C axis torque [Nm]:		-	
Electrical AB axis torque [Nm]:		-	
Electrical B axis torque [Nm]:		-	
Control unit:	Competella PRIME proprietary system		
Minimum cycle time with maximum load [s]:		6	
Electrical power supply:	230 VAC • 50-60Hz • 1P + N + T		
Installed electrical power [kVA]:		3,15	
Pneumatic power supply [bar]:	6		6
Approximate weight [kg]:		150	

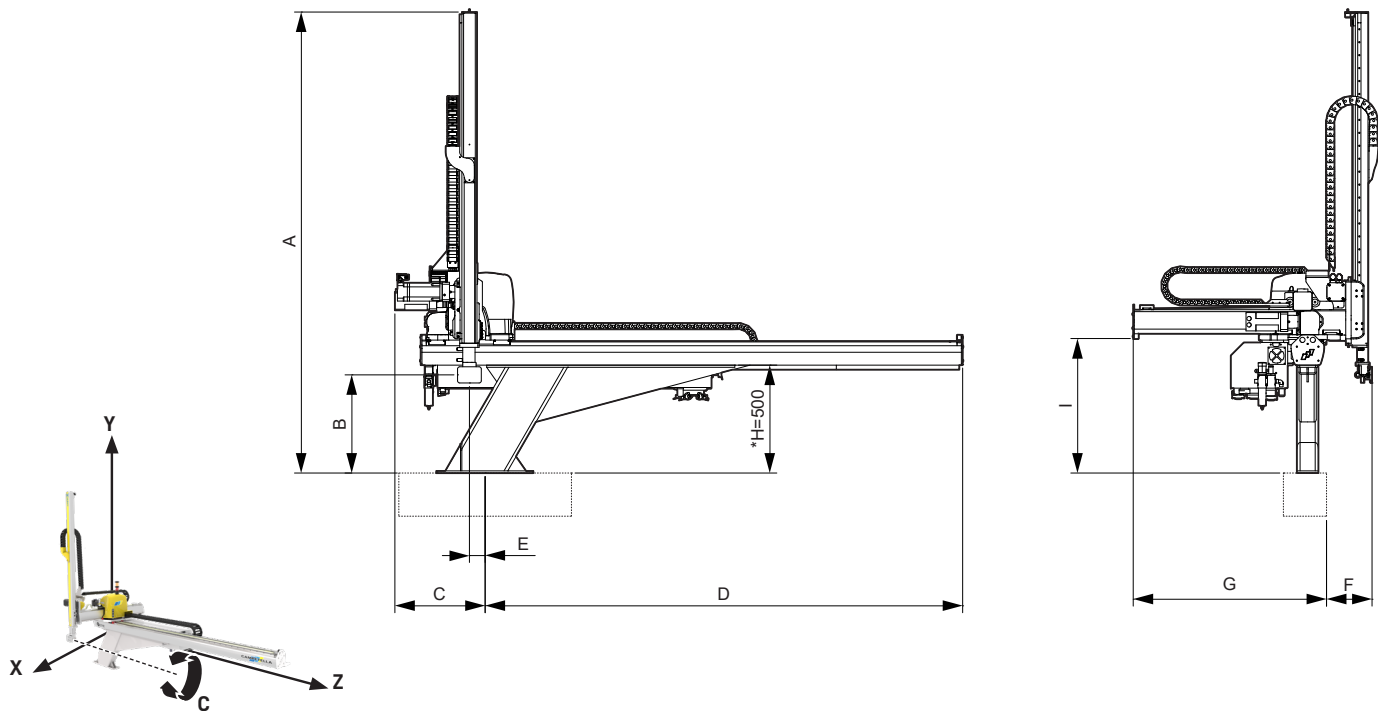

Model	A	B	C	D	E	F	G	H	I
ME1-1-A	2137	455	395	1736	50	211	896	*	621
ME1-2-A	2137	455	395	2236	50	211	896	*	621

The drawings refer to a robot with a pneumatic C-axis and support H = 500mm

*Available standard supports H = 400-500-600mm The dimensions A, B and I vary by difference according to the chosen support

	ME1-1A	ME1-2A
Wrist		
Pneumatic C-axis	●	●
Pneumatic C-axis + Pneumatic AB-axis (1)	○	○
Pneumatic C-axis + Electric B-axis (1)	-	-
Pneumatic C-axis + Pneumatic AB-axis + Electric B-axis (1)	-	-
Electric C-axis + Electric AB-axis (1)	-	-
(1) With maximum load reduction [kg]		
Gripping system Pneumatics		
First vacuum circuit with release blows	●	●
First pressure circuit for mechanical gripper	●	●
Additional vacuum circuits with release blows (n.3 max) (2)	○	○
Additional pressure circuits for mechanical gripper (n.3 max) (2)	○	○
Kit 4 valves 5/2 monostable + 12 input on the wrist	-	-
Kit 4 valves 5/2 bistable + 12 input on the wrist	-	-
Kit 8 valves 5/2 monostable + 12 input on the wrist	-	-
(2) Up to a maximum of 6 pneumatic lines total		
Electronics and Software		
Euromap 67 interface	●	●
Ethernet interface	○	○
USB interface	●	●
Socket for digital signals on the wrist: 5 (Programmable Input/Output) + 2*(Input)	○	○
Socket for user safety signals	●	●
Socket for conveyor belt signals: 1 (Input) + 2 (Output) + 1 (Relais Output)	●	●
Socket for digital signals: 4 (Input) + 3 (Output relay)	●	●
Vertical axis approaching sensor	●	●
Industry 4.0 kit (ethernet router + software)	○	○
Board kit I/O external 16I + 16O with 8mt cable	-	-
Electrical panel on board	●	●
Electrical cabinet on the ground	-	-
Ground cabinet air conditioning	-	-
IML ready with high-voltage cable ⁽⁴⁾	-	-
PLC software integrated into the CNC	-	-
Off-line programming software	-	-
(3) Bound to purchase of kit industry 4.0 (4) Not compatible with electrical axis on the wrist. * 2 dedicated inputs to optional pneumatic AB axis ** Every additional vacuum line absorbs one I/O		

Accessories**IMM connecting cable:**

For Euromap 67 interface, available lengths [m]: 10 (●) 12 (○) 14 (○)

For JIS interface, available lengths [m]: 10 (○)

Electrowelded steel robot support base (●):

Available heights [mm]: 400, 500, 600

Adapter counter plate (○):

Euromap 18 hole pattern available: E7, E8-E9, E10, E11

NOTE: Custom supports and counter plate available on demand

Additional ground base to horizontal axis support(-)**Pushbutton remote control panel for basic functions(○)****EVO console cable winder (-)**

● Standard ○ Optional - Not available

SPECIAL CONFIGURATIONS

Longitudinal discharge application

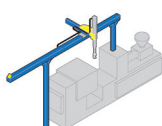

Portal application

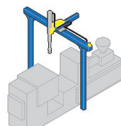

Campetella Robotic Center Srl

Via Grazia Deledda, 40/42 - 62010 Montecassiano (MC) - Italy Tel. (+39) 0733 29891 - Fax. (+39) 0733 298912 - www.campetella.com - commerciale@campetella.it