

# MC4 <sup>EN</sup>

## X-Series<sub>evo</sub>



### CAMPETELLA

Linear Robot MC4 X-Series evo

125  
*Years*

our history, our strength

 *Campetella,  
the right way  
to save energy.*

FOLLOW US:



**X**series  
EVO

# MC4 X-Series evo

## The generously sized robot with maximum performance for large-sized tonnage injection molding machines

A premium level top entry industrial linear robot, accurately designed for ultimate performance on every front. Strength, speed and control are the main features of this last generation manipulator for the maximum productivity.

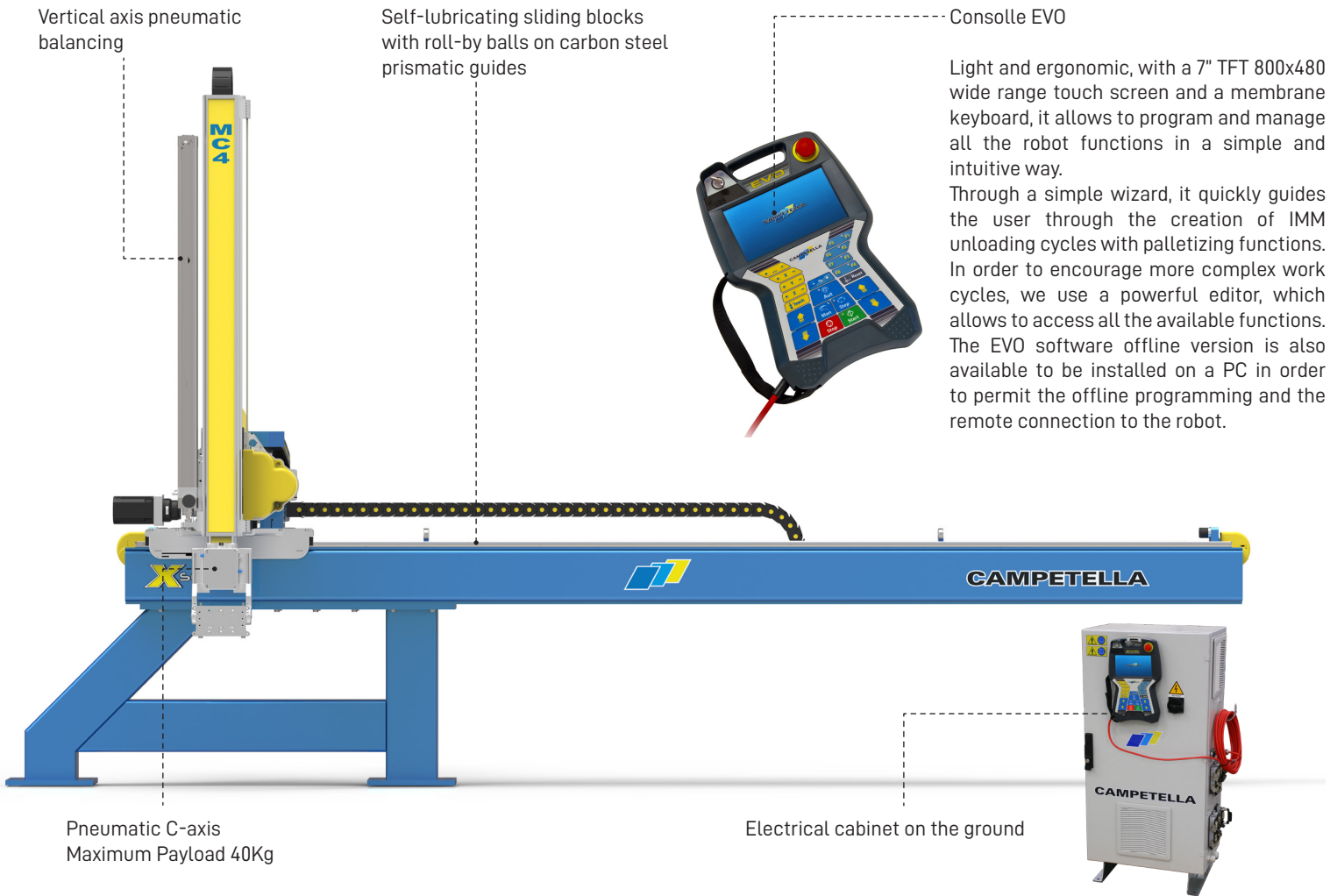

Console EVO

Light and ergonomic, with a 7" TFT 800x480 wide range touch screen and a membrane keyboard, it allows to program and manage all the robot functions in a simple and intuitive way.

Through a simple wizard, it quickly guides the user through the creation of IMM unloading cycles with palletizing functions. In order to encourage more complex work cycles, we use a powerful editor, which allows to access all the available functions. The EVO software offline version is also available to be installed on a PC in order to permit the offline programming and the remote connection to the robot.



Float  
Balanced Axis

Carbon  
Technology

Dynamic  
Vacuum

K.E.R.S.

H.S.I.

3DP  
Device

V.O.S.

Jog Over

### Pneumatic C Axis

The C pneumatic axis facilitates the deposit in plan of the molded pieces picked up from the mold, choosing from the program between two positions (vertical/horizontal).

(sample image may differ from actual supply)

### Pneumatic AB Axis

For applications that require it, it is possible to choose the wrist with the additional pneumatic axis AB, which allows the rotation on its axis of the end of tool arm by choosing from the program between two positions mechanically fixed on the 0° -90° or 0° -180°

(sample image may differ from actual supply)

### Electric B Axis

The B interpolated electrical axis, can be added when both have the need to rotate the wrist on itself in different positions, both in the case of palletization, or simply choose from program the side of the mold on which to intervene.

(sample image may differ from actual supply)

### C and AB electrical Axis

The B interpolated electrical axis, can be added when both have the need to rotate the wrist on itself in different positions, both in the case of palletization, or simply choose from program the side of the mold on which to intervene.

(sample image may differ from actual supply)

# MC4 X-Series evo

	MC4 - 1 H	MC4 - 1 T	MC4 - 2 H	MC4 - 2 T	MC4 - 3 H	MC4 - 3 T	MC4 - 4 H	MC4 - 4 T
<b>Technical specifications:</b>								
Maximum Payload [kg]:	40	25	40	25	40	25	40	25
Vertical axis:	Telescopic (2x)	Telescopic (3x)	Telescopic (2x)	Telescopic (3x)	Telescopic (2x)	Telescopic (3x)	Telescopic (2x)	Telescopic (3x)
Vertical axis pneumatic balancing:	●	●	●	●	●	●	●	●
Z-axis stroke - Horizontal [mm]:	3000	3000	3000	3000	3500	3500	4000	4000
X - axis stroke - Extraction [mm]:	1500	1500	1500	1500	1500	1500	1500	1500
Y-axis stroke - Vertical [mm]:	2000	2000	2400	2580	2400	2580	2400	2580
X, Y, Z axes motion:	AC synchronous brushless servo motors							
X,Y,Z axes guidance system:	Self-lubricating sliding blocks with roll-by balls on carbon steel prismatic guides							
Positioning repeatability [mm]:	± 0,1							
Pneumatic C axis rotation [deg]:	0°/90°							
Electrical C axis rotation [deg]:	0°±180°							
Pneumatic AB axis rotation [deg]:	0°/90° o 0°/180°							
Electrical AB axis rotation [deg]:	0°±360°							
Electrical B axis rotation [deg]:	0° ± 338°							
Pneumatic C axis torque [Nm]:	100	78	100	78	100	78	100	78
Pneumatic AB axis torque [Nm]:	36	20	36	20	36	20	36	20
Electrical C axis torque [Nm]:	43	43	43	43	43	43	43	43
Electrical AB axis torque [Nm]:	39	39	39	39	39	39	39	39
Electrical B axis torque [Nm]:	49	49	49	49	49	49	49	49
Control unit:	Campetella EVO proprietary system							
Minimum cycle time with maximum load [s]:	10	15	10	15	10	15	10	15
Electrical power supply:	400-480 VAC • 50-60Hz • 3P+T							
Installed electrical power [kVA]:	19,79							
Pneumatic power supply [bar]:	6							
Approximate weight [kg]:	1.300							

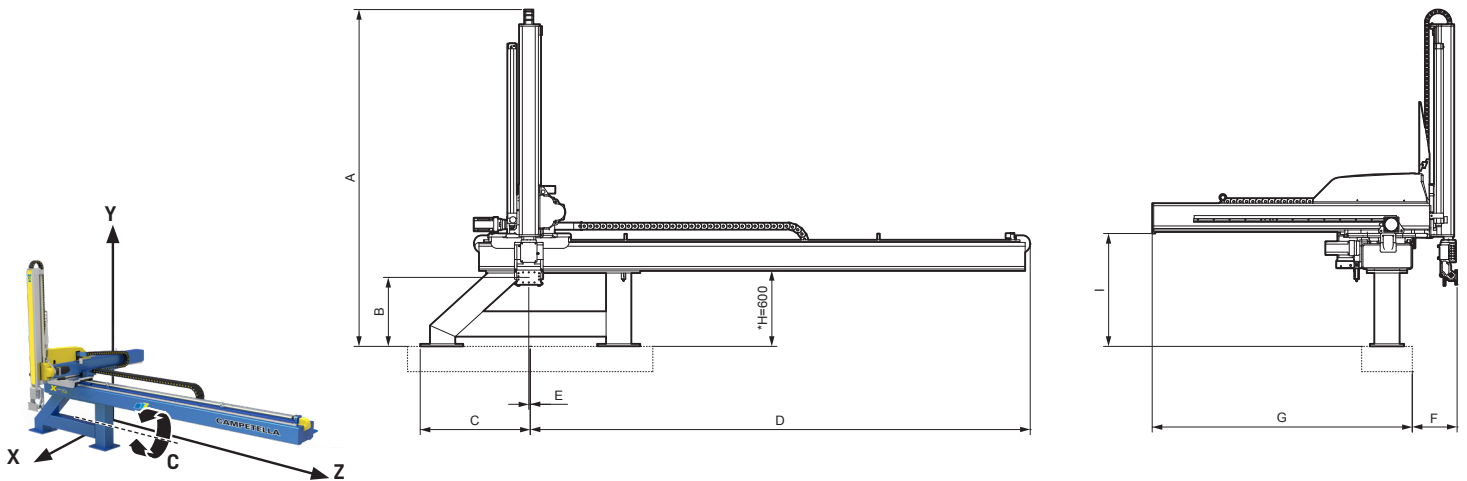

Model	A	B	C	D	E	F	G	H	I
MC4-1-H	2484	545	433	3446	61	335	2077	*	893
MC4-2-H	2664	545	433	3466	61	335	2077	*	893
MC4-3-H	2664	545	433	3966	11	335	2077	*	893
MC4-4-H	2664	545	425	4494	54	335	2077	*	893
MC4-1-T	1935	483	433	3466	61	427	2087	*	893
MC4-2-T	2236	483	433	3466	61	427	2087	*	893
MC4-3-T	2236	483	433	3966	11	427	2087	*	893
MC4-4-T	2236	483	425	4494	54	427	2087	*	893

The drawings refer to a robot with a pneumatic C-axis and support H = 600mm

\*Available standard supports H = 700-800-900mm The dimensions A, B and I vary by difference according to the chosen support

	MC4 - 1 H	MC4 - 1 T	MC4 - 2 H	MC4 - 2 T	MC4 - 3 H	MC4 - 3 T	MC4 - 4 H	MC4 - 4 T
<b>Wrist</b>								
Pneumatic C-axis	●	●	●	●	●	●	●	●
Pneumatic C-axis + Pneumatic AB-axis (1)	○	○	○	○	○	○	○	○
Pneumatic C-axis + Electric B-axis (1)	○	○	○	○	○	○	○	○
Pneumatic C-axis + Pneumatic AB-axis + Electric B-axis (1)	○	○	○	○	○	○	○	○
Electric C-axis + Electric AB-axis (1)	○	○	○	○	○	○	○	○

(1) With maximum load reduction [kg]

<b>Gripping system Pneumatics</b>								
First vacuum circuit with release blows	●	●	●	●	●	●	●	●
First pressure circuit for mechanical gripper	●	●	●	●	●	●	●	●
Additional vacuum circuits with release blows (n.4 max) (2)	○	○	○	○	○	○	○	○
Additional pressure circuits for mechanical gripper (n.4 max) (2)	○	○	○	○	○	○	○	○
Kit 4 valves 5/2 monostable + 12 input on the wrist	○	○	○	○	○	○	○	○
Kit 4 valves 5/2 bistable + 12 input on the wrist	○	○	○	○	○	○	○	○
Kit 8 valves 5/2 monostable + 12 input on the wrist	○	○	○	○	○	○	○	○

(2) Up to a maximum of 6 pneumatic lines total

<b>Electronics and Software</b>								
Euromap 67 interface	●	●	●	●	●	●	●	●
Ethernet interface	●	●	●	●	●	●	●	●
USB interface	●	●	●	●	●	●	●	●
Socket for digital signals on the wrist: 5 (Programmable Input/Output) + 2*(Input)	●	●	●	●	●	●	●	●
Socket for user safety signals	●	●	●	●	●	●	●	●
Socket for conveyor belt signals: 1 (Input) + 2 (Output) + 1 (Relais Output)	●	●	●	●	●	●	●	●
Socket for digital signals: 4 (Input) + 3 (Output relay)	●	●	●	●	●	●	●	●
Vertical axis approaching sensor	○	○	○	○	○	○	○	○
Industry 4.0 kit (ethernet router + software)	○	○	○	○	○	○	○	○
Board kit I/O external 16I + 16O with 8mt cable	○	○	○	○	○	○	○	○
Electrical panel on board	–	–	–	–	–	–	–	–
Electrical cabinet on the ground	●	●	●	●	●	●	●	●
Ground cabinet air conditioning	○	○	○	○	○	○	○	○
IML ready with high-voltage cable (high-voltage wiring for IML predisposition) (3)	○	○	○	○	○	○	○	○
IML predisposition with electrostatic charge generator on the wrist (4)	○	○	○	○	○	○	○	○
PLC software integrated into the CNC	○	○	○	○	○	○	○	○
Off-line programming software	○	○	○	○	○	○	○	○

\* 2 dedicated inputs to optional pneumatic AB axis

(3) Not compatible with electrical axis on the wrist.

<b>Accessories</b>
<b>IMM connecting cable:</b>
For Euromap 67 interface, available lengths [m]: 10 (●) 12 (○) 14 (○)
For JIS interface, available lengths [m]: 10 (○)
<b>Electrowelded steel robot support base (●):</b>
Available heights [mm]: 700, 800, 900
<b>Adapter counter plate (○):</b>
Euromap 18 hole pattern available: E16, E17, E18, E19
NOTE: Custom supports and counter plate available on demand
<b>Additional ground base to horizontal axis support (○):</b>
<b>EVO console cable winder (○)</b>
● Standard ○ Optional – Not available

**SPECIAL CONFIGURATION**

Longitudinal discharge application

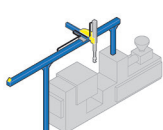

Double IMM application

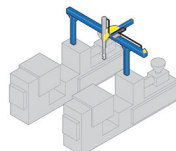

Portal application

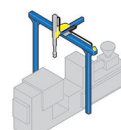

Campetella Robotic Center Srl

Via Grazia Deledda, 40/42 - 62010 Montecassiano (MC) - Italy Tel. (+39) 0733 29891 - Fax. (+39) 0733 298912 - www.campetella.com - commerciale@campetella.it