

MC3 ^{EN}

X-Series



CAMPETELLA

Linear Robot MC3 X-Series evo

125
Years

our history, our strength

 *Campetella,
the right way
to save energy.*

FOLLOW US:



Xseries EVO

MC3 X-Series evo

The suitable robot for medium and large-sized tonnage injection molding machines

A premium level top entry industrial linear robot, accurately designed for ultimate performance on every front. Strength, speed and control are the main features of this last generation manipulator for the maximum productivity.

Vertical axis pneumatic balancing

Self-lubricating sliding blocks with roll-by balls on carbon steel prismatic guides

Consolle EVO

Light and ergonomic, with a 7" TFT 800x480 wide range touch screen and a membrane keyboard, it allows to program and manage all the robot functions in a simple and intuitive way.

Through a simple wizard, it quickly guides the user through the creation of IMM unloading cycles with palletizing functions. In order to encourage more complex work cycles, we use a powerful editor, which allows to access all the available functions. The EVO software offline version is also available to be installed on a PC in order to permit the offline programming and the remote connection to the robot.

Pneumatic C-axis
Maximum Payload 40Kg

Electrical panel on board



Float
Balanced Axis

Carbon
Technology

Dynamic
Vacuum

K.E.R.S.

H.S.I.

3DP
Device

V.O.S.

Jog Over

Pneumatic C Axis

The C pneumatic axis facilitates the deposit in plan of the molded pieces picked up from the mold, choosing from the program between two positions (vertical/horizontal).

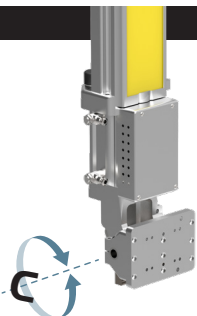

(sample image may differ from actual supply)

Pneumatic AB Axis

For applications that require it, it is possible to choose the wrist with the additional pneumatic axis AB, which allows the rotation on its axis of the end of tool arm by choosing from the program between two positions mechanically fixed on the 0° -90° or 0° -180°

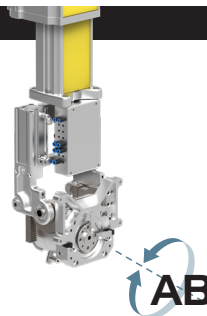

(sample image may differ from actual supply)

Electric B Axis

The B interpolated electrical axis, can be added when both have the need to rotate the wrist on itself in different positions, both in the case of palletization, or simply choose from program the side of the mold on which to intervene.

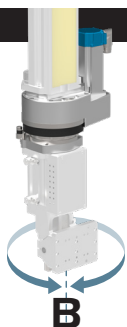

(sample image may differ from actual supply)

C and AB electrical Axis

The B interpolated electrical axis, can be added when both have the need to rotate the wrist on itself in different positions, both in the case of palletization, or simply choose from program the side of the mold on which to intervene.

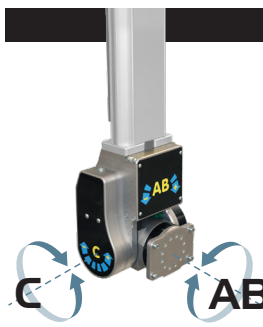

(sample image may differ from actual supply)

MC3 X-Series evo

MC3 - 5 B MC3 - 5 M MC3 - 5 H MC3 - 6 B MC3 - 6 M MC3 - 6 H MC3 - 7 B MC3 - 7 M MC3 - 7 H

Technical specifications:									
Maximum Payload [kg]:	30	40	30	30	40	30	30	40	30
Vertical axis:	Direct	Direct	Telescopic	Direct	Direct	Telescopic	Direct	Direct	Telescopic
Vertical axis pneumatic balancing:	-	•	•	-	•	•	-	•	•
Z-axis stroke - Horizontal [mm]:	2500	2500	2500	3000	3000	3000	3500	3500	3500
X - axis stroke - Extraction [mm]:	1200	1200	1200	1200	1200	1200	1200	1200	1200
Y-axis stroke - Vertical [mm]:	1600	1400	1800	1600	1400	1800	1600	1400	1800
X, Y, Z axes motion:	AC synchronous brushless servo motors								
X,Y,Z axes guidance system:	Self-lubricating sliding blocks with roll-by balls on carbon steel prismatic guides								
Positioning repeatability [mm]:	± 0,1								
Pneumatic C axis rotation [deg]:	0°/90°								
Electrical C axis rotation [deg]:	0°+180°								
Pneumatic AB axis rotation [deg]:	0°/90° o 0°/180°								
Electrical AB axis rotation [deg]:	0°+360°								
Electrical B axis rotation [deg]:	0° + 336°								
Pneumatic C axis torque [Nm]:	78	100	78	78	100	78	78	100	78
Pneumatic AB axis torque [Nm]:	20	36	20	20	36	20	20	36	20
Electrical C axis torque [Nm]:	43	43	43	43	43	43	43	43	43
Electrical AB axis torque [Nm]:	39	39	39	39	39	39	39	39	39
Electrical B axis torque [Nm]:	49	49	49	49	49	49	49	49	49
Control unit:	Campetella EVO proprietary system								
Minimum cycle time with maximum load [s]:	8	10	8	8	10	8	8	10	8
Electrical power supply:	400-480 VAC • 50-60Hz • 3P+T								
Installed electrical power [kVA]:	19,79								
Pneumatic power supply [bar]:	6								
Approximate weight [kg]:	700								

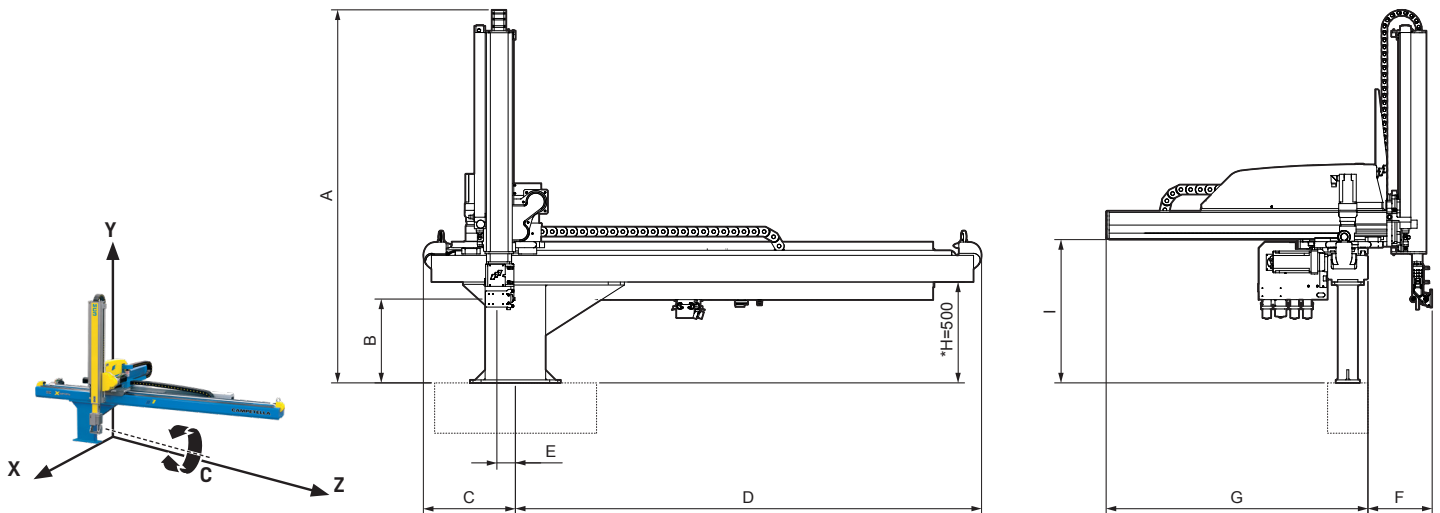

Model	A	B	C	D	E	F	G	H	I
MC3-5-H	2218	419	474	2886	59	337	1606	*	734
MC3-6-H	2218	419	462	3438	48	337	1606	*	734
MC3-7-H	2218	419	462	3918	48	337	1606	*	734
MC3-5-B	2736	464	474	2886	59	255	1620	*	734
MC3-6-B	2736	464	462	3438	48	255	1620	*	734
MC3-7-B	2736	464	462	3918	48	255	1620	*	734
MC3-5-M	2698	397	474	2886	59	323	1620	*	734
MC3-6-M	2698	397	462	3438	48	323	1620	*	734
MC3-7-M	2698	397	462	3918	48	323	1620	*	734

The drawings refer to a robot with a pneumatic C-axis and support H = 500mm

*Available standard supports H = 500-600-700-800mm The dimensions A, B and I vary by difference according to the chosen support

	MC3 - 5 B	MC3 - 5 M	MC3 - 5 H	MC3 - 6 B	MC3 - 6 M	MC3 - 6 H	MC3 - 7 B	MC3 - 7 M	MC3 - 7 H
Wrist									
Pneumatic C-axis	●	●	●	●	●	●	●	●	●
Pneumatic C-axis + Pneumatic AB-axis (1)	○	○	○	○	○	○	○	○	○
Pneumatic C-axis + Electric B-axis (1)	○	○	○	○	○	○	○	○	○
Pneumatic C-axis + Pneumatic AB-axis + Electric B-axis (1)	○	○	○	○	○	○	○	○	○
Electric C-axis + Electric AB-axis (1)	○	○	○	○	○	○	○	○	○

(1) With maximum load reduction [kg]

Gripping system Pneumatics									
First vacuum circuit with release blows	●	●	●	●	●	●	●	●	●
First pressure circuit for mechanical gripper	●	●	●	●	●	●	●	●	●
Additional vacuum circuits with release blows (n.4 max) (2)	○	○	○	○	○	○	○	○	○
Additional pressure circuits for mechanical gripper (n.4 max) (2)	○	○	○	○	○	○	○	○	○
Kit 4 valves 5/2 monostable + 12 input on the wrist	○	○	○	○	○	○	○	○	○
Kit 4 valves 5/2 bistable + 12 input on the wrist	○	○	○	○	○	○	○	○	○
Kit 8 valves 5/2 monostable + 12 input on the wrist	○	○	○	○	○	○	○	○	○

(2) Up to a maximum of 6 pneumatic lines total

Electronics and Software									
Euromap 67 interface	●	●	●	●	●	●	●	●	●
Ethernet interface	●	●	●	●	●	●	●	●	●
USB interface	●	●	●	●	●	●	●	●	●
Socket for digital signals on the wrist: 5 (Programmable Input/Output) + 2*(Input)	●	●	●	●	●	●	●	●	●
Socket for user safety signals	●	●	●	●	●	●	●	●	●
Socket for conveyor belt signals: 1 (Input) + 2 (Output) + 1 (Relais Output)	●	●	●	●	●	●	●	●	●
Socket for digital signals: 4 (Input) + 3 (Output relay)	●	●	●	●	●	●	●	●	●
Vertical axis approaching sensor	○	○	○	○	○	○	○	○	○
Industry 4.0 kit (ethernet router + software)	○	○	○	○	○	○	○	○	○
Board kit I/O external 16I + 16O with 8mt cable	○	○	○	○	○	○	○	○	○
Electrical panel on board	●	●	●	●	●	●	●	●	●
Electrical cabinet on the ground	○	○	○	○	○	○	○	○	○
IML ready with high-voltage cable (high-voltage wiring for IML predisposition) (3)	○	○	○	○	○	○	○	○	○
PLC software integrated into the CNC	○	○	○	○	○	○	○	○	○
Off-line programming software	○	○	○	○	○	○	○	○	○

* 2 dedicated inputs to optional pneumatic AB axis

(3) Not compatible with electrical axis on the wrist.

Accessories
IMM connecting cable:
For Euromap 67 interface, available lengths [m]: 10 (●) 12 (○) 14 (○)
For JIS interface, available lengths [m]: 10 (○)
Electrowelded steel robot support base (●):
Available heights [mm]: 500 , 600 , 700 , 800
Adapter counter plate (○) :
Euromap 18 hole pattern available: E11 , E12-E13
NOTE: Custom supports and counter plate available on demand
Additional ground base to horizontal axis support (○):
Additional ground base to horizontal axis support(○)
EVO console cable winder (○)
● Standard ○ Optional – Not available

SPECIAL CONFIGURATION

Longitudinal discharge application

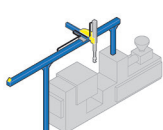

Double IMM application

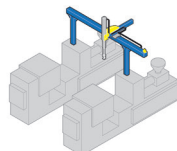

Portal application

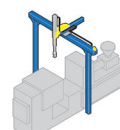

Campetella Robotic Center Srl