

# MC2<sup>EN</sup>

## E-Series



**CAMPETELLA**

Linear Robot MC2 E-Series evo

**125**  
*Years*

our history, our strength

 **Campetella,**  
the right way  
to save energy.

FOLLOW US:



**e**series  
EVO

# MC2 E-Series evo

## The suitable robot for small and medium-sized tonnage injection molding machines

The MC2 E-Series is a last generation industrial linear robot, designed for high performance, accuracy and reliability. The most advanced functions for the ultimate level of control.

Roller bearings on hardened steel prismatic guides and sliding blocks with roll-by balls

Console EVO

Light and ergonomic, with a 7" TFT 800x480 wide range touch screen and a membrane keyboard, it allows to program and manage all the robot functions in a simple and intuitive way.

Through a simple wizard, it quickly guides the user through the creation of IMM unloading cycles with palletizing functions. In order to encourage more complex work cycles, we use a powerful editor, which allows to access all the available functions. The EVO software offline version is also available to be installed on a PC in order to permit the offline programming and the remote connection to the robot.

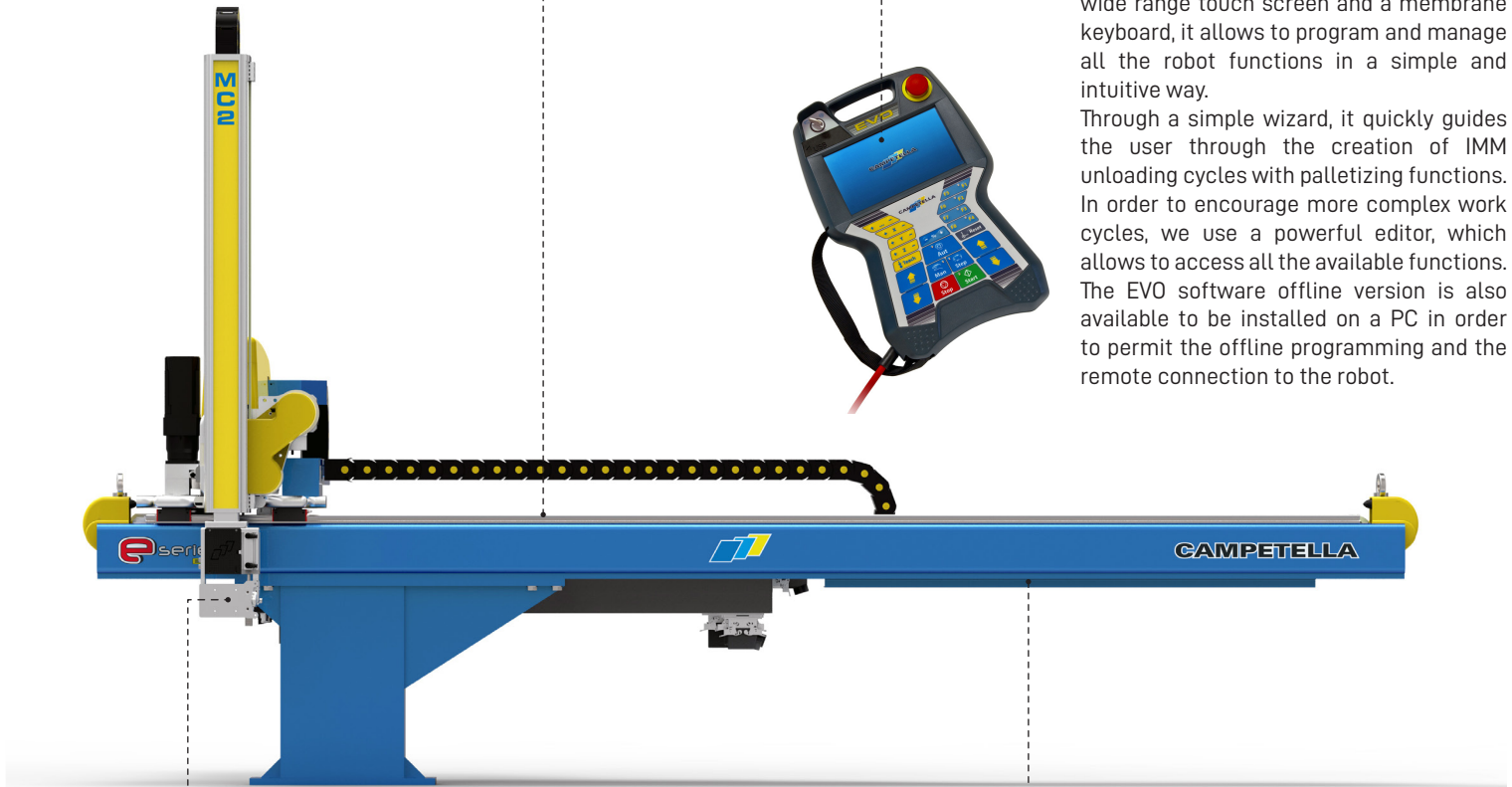

Pneumatic C-axis  
Maximum Payload 9Kg

Electrical panel on board



Float  
Balanced Axis

Carbon  
Technology

Dynamic  
Vacuum

K.E.R.S.

H.S.I.

3DP  
Device

V.O.S.

Jog Over

### Pneumatic C Axis

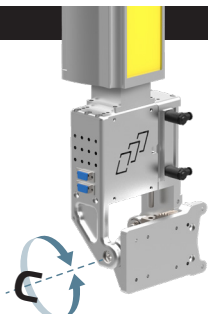

The C pneumatic axis facilitates the deposit in plan of the molded pieces picked up from the mold, choosing from the program between two positions (vertical/horizontal).

(sample image may differ from actual supply)

### Pneumatic AB Axis



For applications that require it, it is possible to choose the wrist with the additional pneumatic axis AB, which allows the rotation on its axis of the end of tool arm by choosing from the program between two positions mechanically fixed on the 0° -90° or 0° -180°

(sample image may differ from actual supply)

### Electric B Axis



The B interpolated electrical axis, can be added when both have the need to rotate the wrist on itself in different positions, both in the case of palletization, or simply choose from program the side of the mold on which to intervene.

(sample image may differ from actual supply)

# MC2 E-Series evo

	MC2 - 1 A	MC2 - 1 L	MC2 - 2 A	MC2 - 2 L	MC2 - 3 A	MC2 - 3 L
<b>Technical specifications</b>						
Maximum Payload [kg]:	9	9	9	9	9	9
Vertical axis:	Direct	Telescopic	Direct	Telescopic	Direct	Telescopic
Vertical axis pneumatic balancing:	-	-	-	-	-	-
Z-axis stroke - Horizontal [mm]:	2000	2000	2500	2500	3000	3000
X-axis stroke - Extraction [mm]:	1000	1000	1000	1000	1000	1000
Y-axis stroke - Vertical [mm]:	1400	1600	1400	1600	1400	1600
X, Y, Z axes motion:	AC synchronous brushless servo motors					
X,Y,Z axes guidance system:	Roller bearings on hardened steel prismatic guides and sliding blocks with roll-by balls					
Positioning repeatability [mm]:	± 0,1					
Pneumatic C axis rotation [deg]:	0°/90°					
Electrical C axis rotation [deg]:	-					
Pneumatic AB axis rotation [deg]:	0°/90° o 0°/180°					
Electrical AB axis rotation [deg]:	-					
Electrical B axis rotation [deg]:	0° ± 330°					
Pneumatic C axis torque [Nm]:	21					
Pneumatic AB axis torque [Nm]:	5					
Electrical C axis torque [Nm]:	-					
Electrical AB axis torque [Nm]:	-					
Electrical B axis torque [Nm]:	15					
Control unit:	Campetella EVO proprietary system					
Minimum cycle time with maximum load [s]:	8					
Electrical power supply:	230 VAC • 50-60Hz • 1P + N + T					
Installed electrical power [kVA]:	5,96					
Pneumatic power supply [bar]:	6					
Approximate weight [kg]:	450					

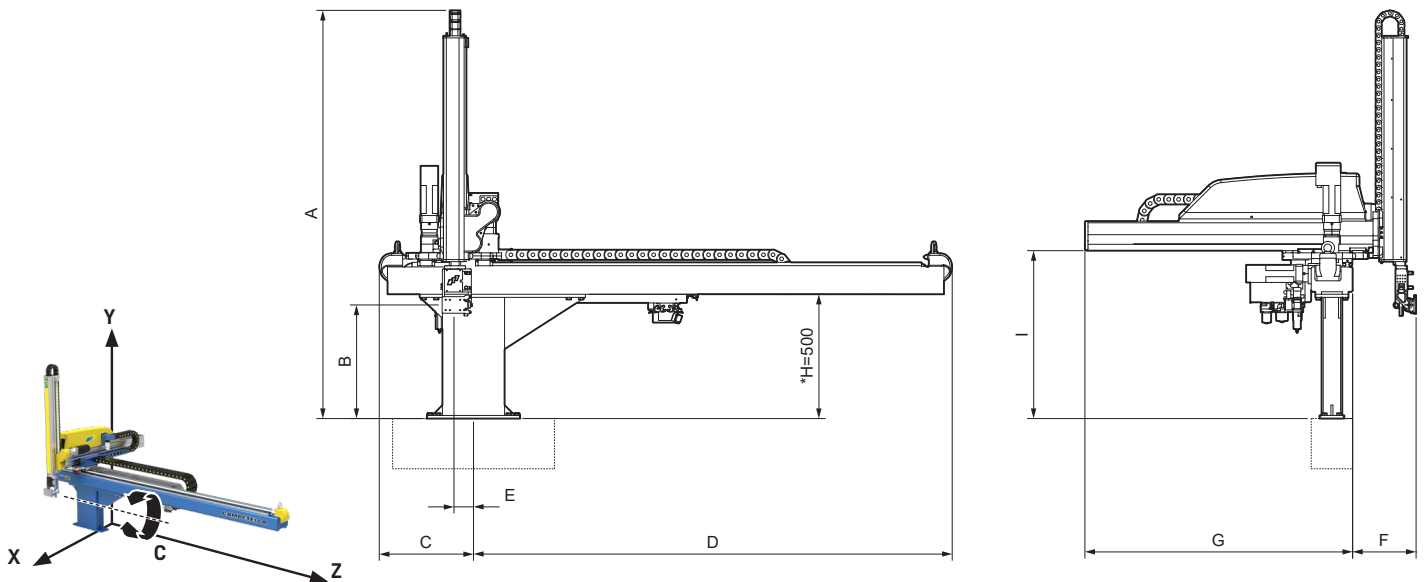

Model	A	B	C	D	E	F	G	H	I
MC2-1-A	2352	450	455	2311	89	295	1303	*	710
MC2-2-A	2352	450	433	2814	67	295	1303	*	710
MC2-3-A	2352	450	433	3354	75	295	1303	*	710
MC2-1-L	1870	448	455	2311	89	295	1303	*	710
MC2-2-L	1870	448	433	2814	67	295	1303	*	710
MC2-3-L	1870	448	440	3345	75	295	1303	*	710

The drawings refer to a robot with a pneumatic C-axis and support H = 500mm

\*Available standard supports H = 500-600-700-800mm The dimensions A, B and I vary by difference according to the chosen support

	MC2-1A	MC2-1L	MC2-2A	MC2-2L	MC2-3A	MC2-3L
<b>Wrist</b>						
Pneumatic C-axis	●	●	●	●	●	●
Pneumatic C-axis + Pneumatic AB-axis (1)	○	○	○	○	○	○
Pneumatic C-axis + Electric B-axis (1)	○	○	○	○	○	○
Pneumatic C-axis + Pneumatic AB-axis + Electric B-axis (1)	○	○	○	○	○	○
Electric C-axis + Electric AB-axis (1)	-	-	-	-	-	-

(1) With maximum load reduction [kg]

<b>Gripping system Pneumatics</b>						
First vacuum circuit with release blows	●	●	●	●	●	●
First pressure circuit for mechanical gripper	●	●	●	●	●	●
Additional vacuum circuits with release blows (n.4 max) (2)	○	○	○	○	○	○
Additional pressure circuits for mechanical gripper (n.4 max) (2)	○	○	○	○	○	○
Kit 4 valves 5/2 monostable + 12 input on the wrist	○	○	○	○	○	○
Kit 4 valves 5/2 bistable + 12 input on the wrist	○	○	○	○	○	○
Kit 8 valves 5/2 monostable + 12 input on the wrist	○	○	○	○	○	○

(2) Up to a maximum of 6 pneumatic lines total

<b>Electronics and Software</b>						
Euromap 67 interface	●	●	●	●	●	●
Ethernet interface	●	●	●	●	●	●
USB interface	●	●	●	●	●	●
Socket for digital signals on the wrist: 5 (Programmable Input/Output) + 2*(Input)	●	●	●	●	●	●
Socket for user safety signals	●	●	●	●	●	●
Socket for conveyor belt signals: 1 (Input) + 2 (Output) + 1 (Relais Output)	●	●	●	●	●	●
Socket for digital signals: 4 (Input) + 3 (Output relay)	●	●	●	●	●	●
Vertical axis approaching sensor	○	○	○	○	○	○
Industry 4.0 kit (ethernet router + software)	○	○	○	○	○	○
Board kit I/O external 16I + 16O with 8mt cable	○	○	○	○	○	○
Electrical panel on board	●	●	●	●	●	●
Electrical cabinet on the ground	-	-	-	-	-	-
Ground cabinet air conditioning	-	-	-	-	-	-
IML ready with high-voltage cable (high-voltage wiring for IML predisposition) (3)	○	○	○	○	○	○
PLC software integrated into the CNC	○	○	○	○	○	○
Off-line programming software	○	○	○	○	○	○

\* 2 dedicated inputs to optional pneumatic AB axis

(3) Not compatible with electrical axis on the wrist.

**Accessories****IMM connecting cable:**

For Euromap 67 interface, available lengths [m]: 10 (●) 12 (○) 14 (○)

For JIS interface, available lengths [m]: 10 (○)

**Electrowelded steel robot support base (●):**

Available heights [mm]: 500 , 600 , 700 , 800

**Adapter counter plate (-) :**

Euromap 18 hole pattern available: E8-E9 , E10 , E11 , E12-E13

NOTE: Custom supports and counter plate available on demand

**Additional ground base to horizontal axis support(○)****Pushbutton remote control panel for basic functions (-)****EVO console cable winder (○)**

● Standard ○ Optional - Not available

**SPECIAL CONFIGURATION**

Longitudinal discharge application

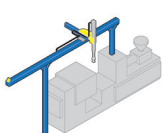

Double IMM application

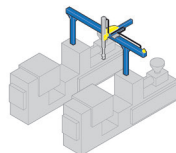

Portal application

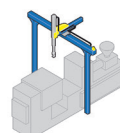

Campetella Robotic Center Srl